

In-Depth Comparison: Torqeedo Travel 1103C vs ePropulsion Spirit 1.0 Plus

Chandler Xu



Torqeedo announced [Travel 1103C](#) 3HP electric outboard motor in 2018 METS and started to deliver in early 2019. I was there in 2018 METS at its debut and it did impress me with the noise-control. The previous model Travel 1003C has a reduction gear that emits [a whining noise](#) at almost any speed. Travel 1103C is the first direct-drive outboard within Torqeedo, and it entirely solves the noise issue.

ePropulsion adopted direct-drive technology since day one and they launched Spirit 1.0 at 2014 METS, which is 5 years ahead of Torqeedo on direct-drive outboard technology. To compete with the new Travel 1103C, ePropulsion announced [Spirit 1.0 Plus](#) in 2019 MEST with a larger battery and began shipping in early 2020.

Here's the big question: Both products are available on the market but should you buy Torqeedo Travel 1103C or ePropulsion Spirit 1.0 Plus? Let's find out.

Runtime: Spirit 1.0 Plus Wins

At full throttle, Travel 1103C can go 50 min and Spirit 1.0 Plus 75 min, which is 50% more than Travel 1103C. This is no doubt the greatest advantage of Spirit 1.0 Plus against Travel 1103C.

Integrated Battery: Spirit 1.0 Plus Wins

The capacity of Spirit 1.0 Plus battery is 1276Wh, and it's 39% larger than Travel 1103C's 915Wh battery. In addition, Spirit 1.0 Plus's battery can float so you never worry about losing it when it drops into the water. Check this video: <https://youtu.be/p95q1ozzxMw?t=25>

Tiller: Draw

Spirit 1.0 Plus's tiller is foldable and integrated with the motor, so it's easy to carry and pack up. The problem is the Spirit 1.0 Plus tiller can go up to 38° only. When you tilt the motor and you have limited space at the stern, it would be awkward for Spirit 1.0 Plus's tiller. Travel 1103C's tiller can go up to 70°, so it's much more user-friendly when tilting up the motor.

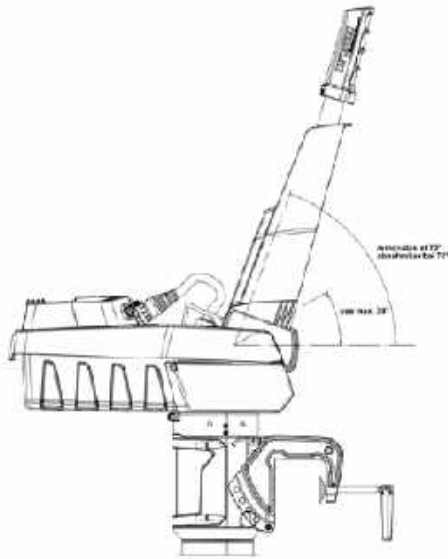

Travel 1103C

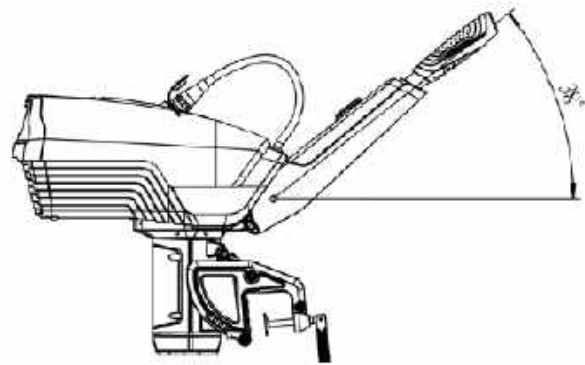

Spirit 1.0 Plus

Note: ePropulsion is redesigning the Spirit tiller and will announce a new model in Q4 2020. I hope it fixes this problem.

Installation Process: Spirit 1.0 Plus Wins

The installation of Spirit 1.0 Plus couldn't be easier. Clamp the outboard, unfold the tiller, and put on the battery with a latch, you're all set. [Check this video](#) from 3:01. For Travel 1103C, it takes three more steps because the tiller is not integrated with the motor and it requires a separate lock pin to secure the battery -- not a latch like Spirit battery. [Check this video](#) from 6:19. You need to connect the tiller to the motor, then you connect the tiller communication cable to the motor, and lastly, you use a lock pin to secure the battery. It's not a major problem to take three more steps when installing Travel 1103C, but once you experience how easy it is to install Spirit 1.0 Plus, you will love it.



Spirit 1.0 Plus has 2 big parts: motor and battery. The tiller is integrated with the motor.



Travel 1103C has 3 big parts: motor, tiller and battery.

Charging Time: Spirit 1.0 Plus Wins

From dead to full, it takes 8.5 hours to charge Spirit 1.0 Plus and 10.5 hours to Travel 1103C. Normally, people don't use the battery to less than 10% capacity so the actual charging time is less than the full charge time. When you charge overnight, a 10.5-hour full charge time means there's a chance the Travel 1103C battery is not full the next morning when you have to leave. With the Spirit 1.0 Plus, it's much less likely to happen.

Solar Charging: Spirit 1.0 Plus Wins

Solar charging is very useful for portable electric outboards. You can't do it with the normal charger but a solar charger with MPPT function. Travel 1103C's solar charger is only 50W, which is too small and is not practical. Spirit 1.0 Plus's solar charger allows 180W solar charging, way larger than Travel 1103C.

The cost of a Spirit solar charger is only \$99, and you could buy 3rd-party solar panels from Amazon at an affordable price. For Travel 1103C, your only option is [a 50W solar charging bundle](#) for \$749, and you can't buy the solar charger without the solar panel.

External Battery: Spirit 1.0 Plus Wins

The operating voltage of Spirit 1.0 Plus is 48V, and ePropulsion develops [a power cable adapter](#) to convert its proprietary connector to O-ring two-terminal connectors that work with external lithium and lead-acid batteries. This gives Spirit 1.0 Plus great battery options to extend the range. Officially, ePropulsion recommends its [E-Series LiFePO4 batteries](#) to extend the range of Spirit 1.0 Plus, and you have three capacity 2kWh, 4kWh, and 9kWh with \$0.5 unit price. That's a fantastic add-on to Spirit 1.0 Plus.

Travel 1103C doesn't have the power cable adapter accessory to work with external batteries and its operating voltage is 29.6V so you can't build a battery pack from 12V external batteries.

The compatibility with external batteries is very useful for rental boats that require long runtime.

Power Cable Connector: Spirit 1.0 Plus Wins

The power cable connector is very important for portable electric outboard but it's easy to ignore before you make a purchase. If you ask me where the most fragile part of a portable electric outboard is, I would say it's the power cable connector. You connect and disconnect dozens or even hundreds of times a year.



The most claimed warranty issue of old Spirit 1.0 is the broken connector. To fix that, ePropulsion works with Amphenol and co-designs the new power connector made of high-quality stainless steel and processed by PVD technology. It is durable and corrosion-resistant. I don't see that durability on Travel 1103C's power cable connector which is still made of engineering plastic.

Electric outboard has longer service life than the four-stroke outboard, so the durability of the power cable connector is quite important to buyers. For large electric outboards, they use Anderson connectors and it's easy to make a replacement. However, portable electric outboards like Travel 1103C and Spirit 1.0 Plus, they don't use Anderson connectors but a proprietary one-terminal connector for a quick and easy connection. When it's broken, it's a painful process to wait for the parts, and not every dealer has the skills to make a replacement. The durability of the power connector is the detail you can't ignore before a purchase.

Lower Unit: Spirit 1.0 Plus Wins

The biggest change from Travel 1003C to Travel 1103C is the direct-drive motor. Yes, Torqeedo did it to deliver its first direct-drive Travel to the market. However, the size of its lower unit gets larger. Actually, the lower unit of Travel 1103C is 27% longer and 14% wider than Spirit 1.0 Plus, which means more

water drag. I took the picture below in METS 2019 and you could see the size difference between the two lower units.



In addition, the lower unit of Spirit 1.0 Plus is made of full aluminum alloy, but the lower unit of Travel 1103C is half engineering plastic and half aluminum alloy.

Mobile App: Draw

I get challenged often that Spirit 1.0 Plus has no GPS and mobile App but Travel 1103C does. I know it looks pretty biased to give it draw here, but I firmly believe I'm right. Come on, it's only 3HP! Not 30HP, not 300HP. How far and how fast will you go with a 3HP outboard? A 3HP outboard only allows you to travel in a short distance at a low speed. It's not a strong need to know the GPS route and speed at 3HP. Actually, there're all kinds of GPS tracking App can do a better job than Torqeedo mobile App. And don't forget that the App development cost and GPS device cost also increase the overall cost of Travel 1103C.

Cost: Spirit 1.0 Plus Wins

In the United States, the retail price of Spirit 1.0 Plus is \$1,999, and Travel 1103C \$2,699. It's a \$700 difference. In Europe, the retail price of Spirit 1.0 is €1,899 and Travel 1103C € 2,199.

Conclusion

In 2020, you definitely should buy Spirit 1.0 Plus from the performance and design perspectives. With Spirit 1.0 Plus, you gain 50% more runtime, pay \$700 less than Travel 1103C, and have features like floatable battery, 180W solar charging, and integrated folding tiller, etc.

Comparison Summary

	Travel 1103C	Spirit 1.0 Plus
Horsepower	3HP	3HP
Weight	17.3 kg / 38.1 lbs	19.3 kg / 42.5 lbs
Full-throttle runtime	50 min	75 min
Integrated and Foldable Tiller	No	Yes
Tiller Angle	70°	38°
Battery Capacity	915Wh	1276Wh
Floatable Battery	No	Yes
External Battery Compatability	No	Yes
Solar Charging	50W	180W
Lower Unit Size	Length: 323 mm / 12.7 in Diameter: 124 mm / 4.9 in	Length: 254 mm / 10 in Diameter: 108 mm / 4.3 in
Lower Unit Material	Half Aluminum Alloy, half engineering plastic.	Full aluminum alloy.
Power cable connector	Plastic	Stainless Steel
Official Mobile App	Yes	No
Retail Price	North America: \$2,699 Europe: €2,199	North America: \$1,999 Europe: €1,899